



MTG/MTY110A

Non-Insulated Type Thyristor Module

Features

Non-insulated type, Baseboard servers as the public electrode
 Full crimping structure, super temperature characteristics and power cycle capability
 Lower forward voltage drop

Application

AC/DC Motor Control
 Various rectifying power suppliers
 Industry Heating Regulation
 Light Dimming
 Contactless Switches

$I_{T(AV)}$	110 A
V_{DRM}/V_{RRM}	400-2600 V
I_{TSM}	3.2KA
I^2T	52.2KA ² S

Symb.		parameter	Test Conditions	$T_{J(c)}$	Value	Unit
Current Ratings	$I_{T(AV)}$	average on-state current	180° half sine wave 50Hz Single side cooled $T_c=90^\circ C$	125	110	A
	$I_{T(RMS)}$	RMS on-state current		125	157	A
	I_{TSM}	Surge on-state current	10ms half sine wave $V_R=0.6V_{RRM}$	125	3.20	KA
	I^2t	I ² T for fusing coordination		125	52.2	KA ² S
Characteristics	V_{DRM} V_{RRM}	Repetitive peak off-state voltage Repetitive peak reverse voltage	$V_{DRM}\&V_{RRM}$ tp=10ms $V_{DSM}\&V_{RSM}=V_{DRM}\&V_{RRM}+100V$	125	400-2600	V
	I_{DRM} I_{RRM}	Repetitive peak current	$V_{DM}=V_{DRM}$ $V_{RM}=V_{RRM}$	125	Max.8	mA
	V_{TO}	Threshold voltage		125	Max.0.80	V
	V_{TM}	Peak on-state voltage	$I_{TM}=300A$	25	Max.1.67	V
	r_T	On-state slop resistance		125	Max.2.45	mΩ
	I_H	Holding current	$V_A=12V, I_A=1A$	25	Min.20 Max.150	ma
Dynamic Parameters	dv/dt	Critical rate of rise of off-state voltage	$V_{DM}=67\%V_{DRM}$	125	Max.800	V/μs
	di/dt	Critical rate of rise of on-state current	Gate trigger current amplitude $I_{GM}=1.5A$, gate trigger current rise time $t_r \leq 1\mu s$	125	Max.100	A/μs
Gate Parameters	I_{GT}	Gate trigger current	$V_A=12V, I_A=1A$	25	30-100	mA
	V_{GT}	Gate trigger voltage		25	0.8-2.5	V
	V_{GD}	Non-trigger gate voltage	$V_{DM}=67\%V_{DRM}$	125	Min.0.2	V

Thermal & Mechanical Data

Symb.	parameter	Test Conditions	Value	Unit
$R_{th(j-c)}$	Thermal resistance Junction to case	single side cooled	Max.0.250	°C/W
$R_{th(c-h)}$	Thermal resistance case to heat sink	single side cooled	Max.0.1	°C/W
F_m	Terminal connection torque(M5)		Min.4.0	N m
	Mounting force (M6)		Max.6.0	N m
T_{stg}	Stored temperature		-40+125	°C
W_t	Weight		220	g

Outline:

M36

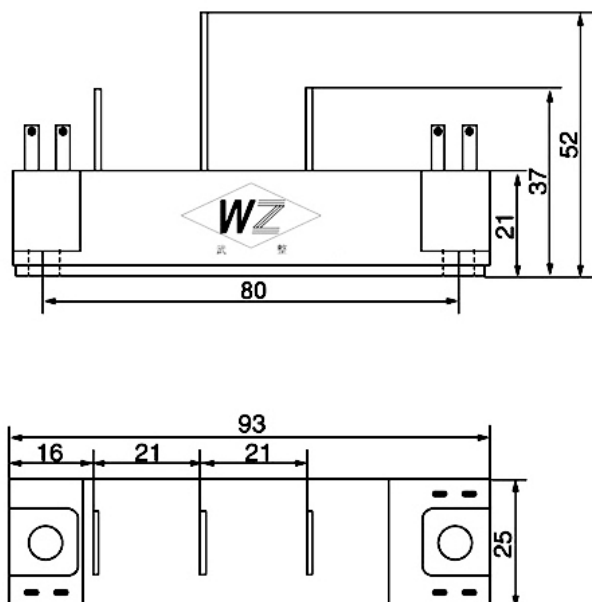

M37

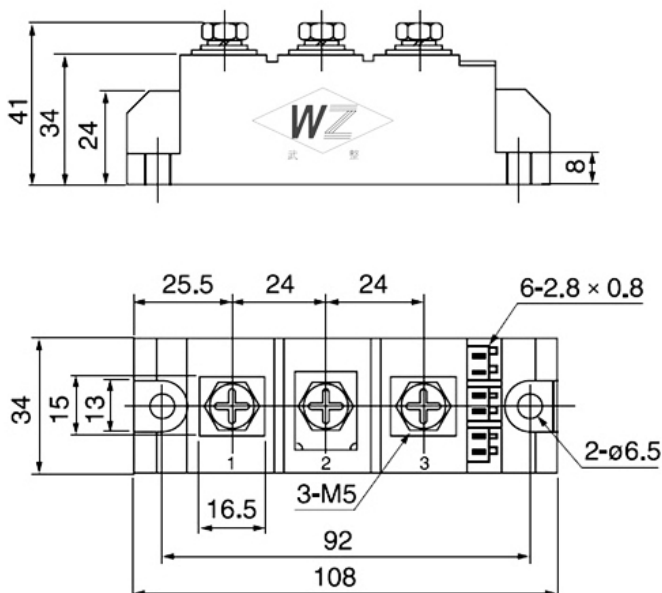

M38

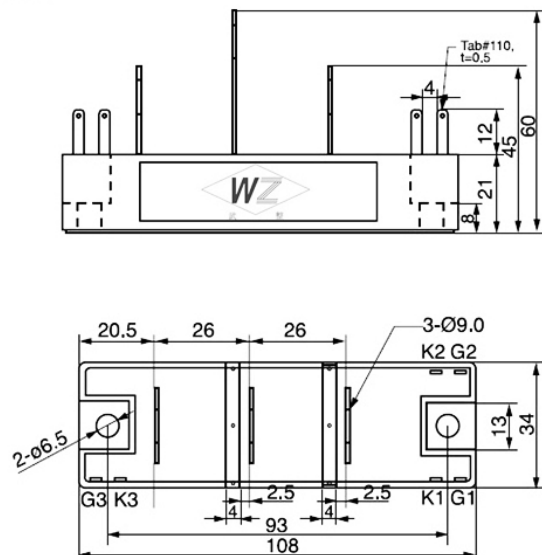

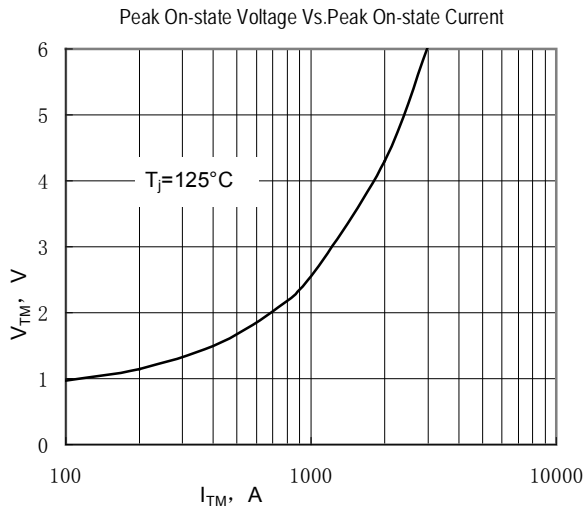

Fig.1

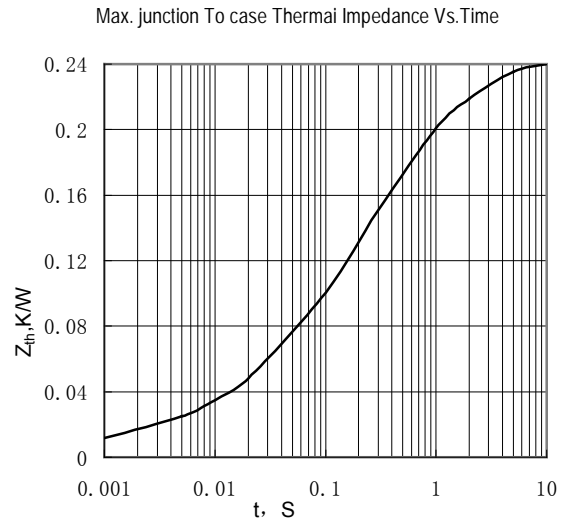

Fig.2

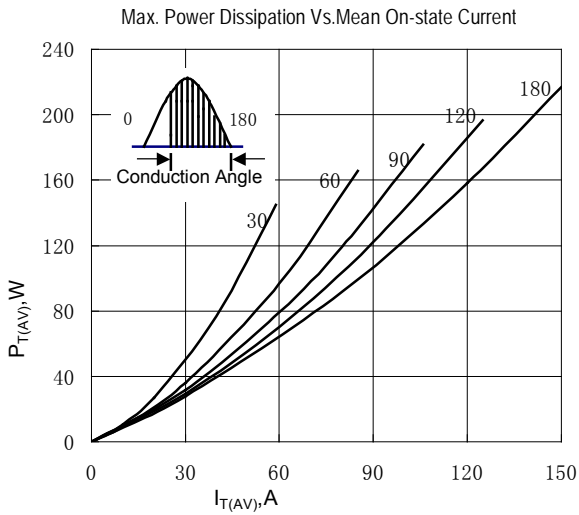

Fig.3

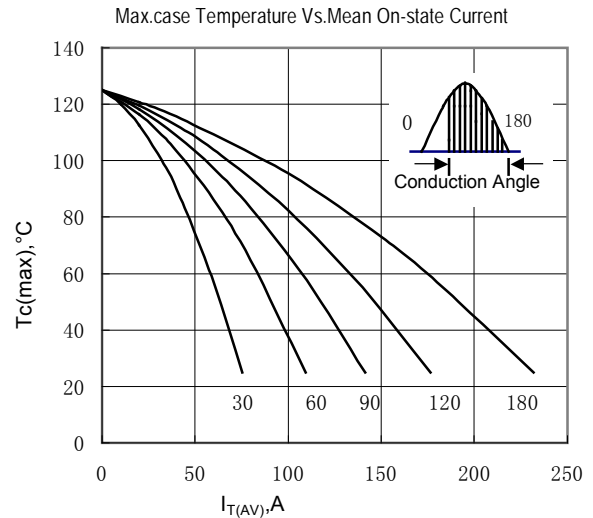

Fig.4

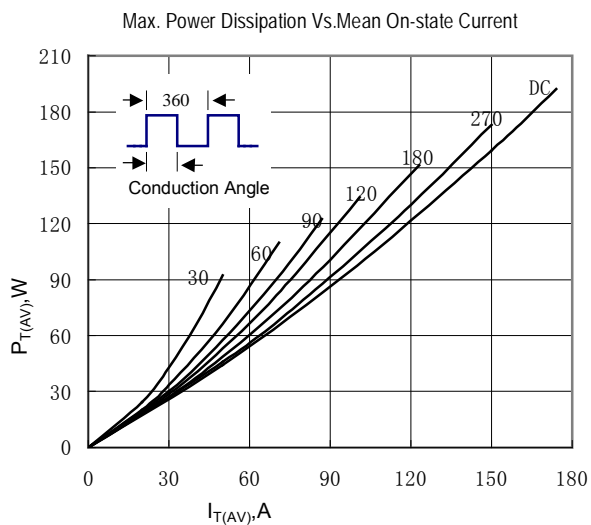

Fig.5

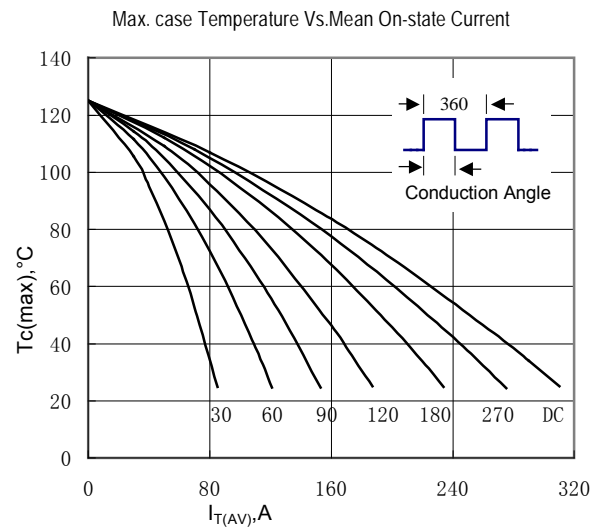

Fig.6

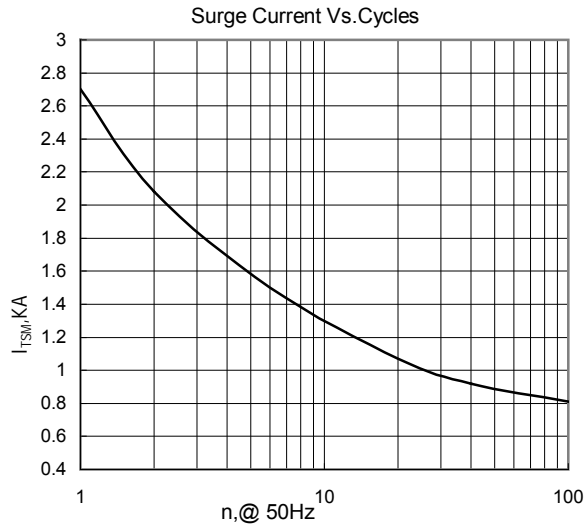

Fig.7

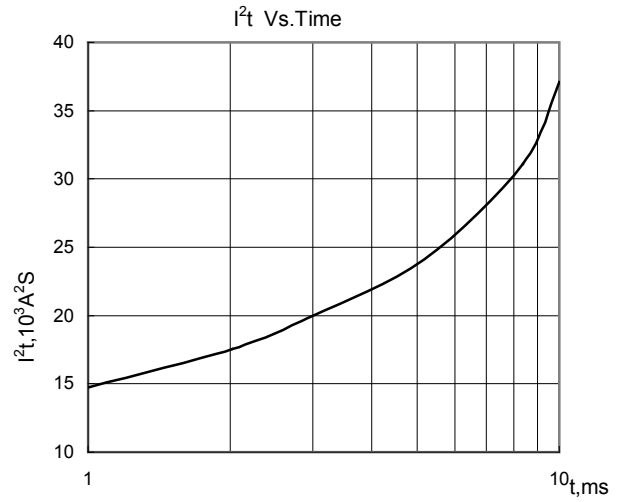

Fig.8

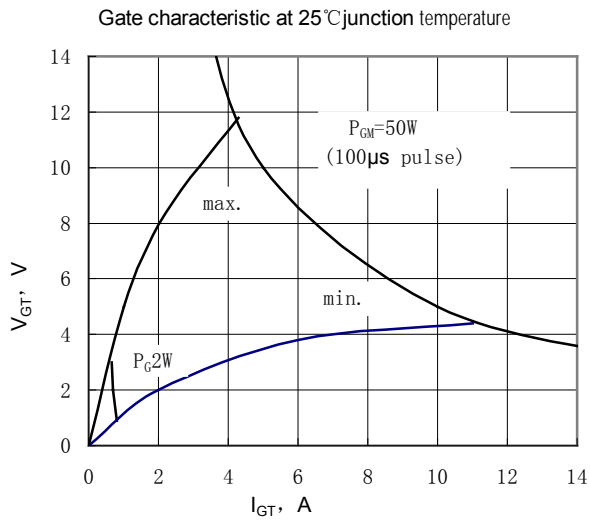

Fig.9

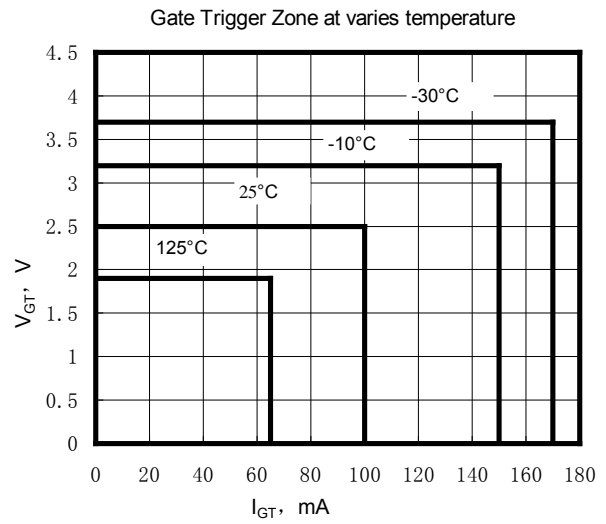

Fig.10

Wuhan Wuzheng Rectifier Co., Ltd

Add: NO. 73 Gaoxin Five Road, East Lake New Technology Development Zone, Wuhan City, Hubei province.

Tel : 86-27-87001995

Fax: 86-27-87180920

Email: info@techele.com

Web: www.techele.com/en

cntechele.en.alibaba.com