

MDC/MDA/MDK/MDX1000A DIODE MODULE



Features

Isolated mounting base 2500V
Increased power cycling capability
Space and weight savings

Application

AC/DC Motor drives
Various rectifiers
DC supply for PWM inverter

$I_{F(AV)}$	1000A
V_{RRM}	400-2600 V
I_{FSM}	20KA
I^2t	1650KA ² S

Symb.	parameter	Test Conditions	$T_J(^{\circ}C)$	Value	Unit	
Current Ratings	$I_{F(AV)}$	average forward current	180 ° half sine wave 50Hz Single side cooled, $T_C=60^{\circ}C$	150	1000	A
	$I_{F(RMS)}$	RMS forward current		150	1570	A
	I_{FSM}	Surge forward current	10ms half sine wave	150	20	KA
	I^2t	I^2t for fusing coordination	$VR=0.6VRRM$	150	2040	KA ² S
Characteristics	V_{RRM}	Repetitive peak reverse voltage	$V_{RRM} tp=10ms$ $V_{RSM}=V_{RRM}+200V$	150	400-2600	V
	I_{RRM}	Repetitive peak current	$V_{RM}=V_{RRM}$	150	Max.50	Ma
	V_{FM}	Peak on-state voltage	$I_{FM}=3000A$	25	Max.1.82	V
	V_{FO}	Threshold voltage		150	Max.0.75	V
	r_F	Forward slop resistance		150	Max.0.31	mΩ

Thermal & Mechanical Data

Symb.	parameter	Test Conditions	Value	Unit
$R_{th(j-c)}$	Thermal resistance Junction to case	At 180 3sine wave, single side cooled	Max.0.080	°C/W
$R_{th(c-h)}$	Thermal resistance case to heat sink	At 180 3sine wave, single side cooled		°C/W
V_{iso}	Isolated voltage	50Hz,R.M.S.,t=1min,Iso:1mA(max)	Min.2500	V
F_m	Terminal connection torque(M5)		Typ.14	N m
	Mounting force (M6)		Typ.12	N m
T_{stg}	Stored temperature		-40+125	°C
W_t	Weight		3800	g

Outline:

M7

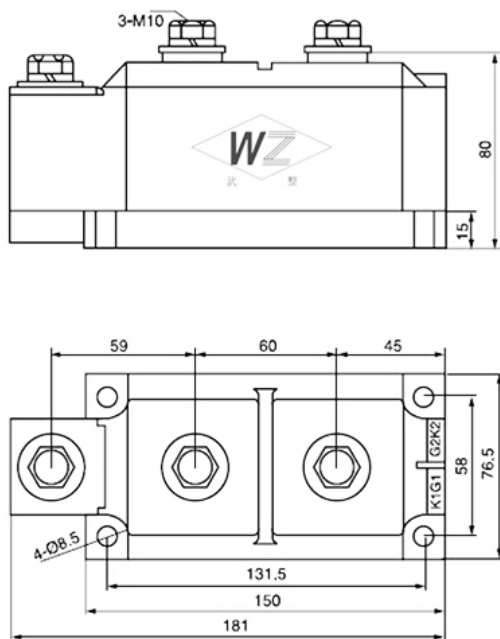

M11

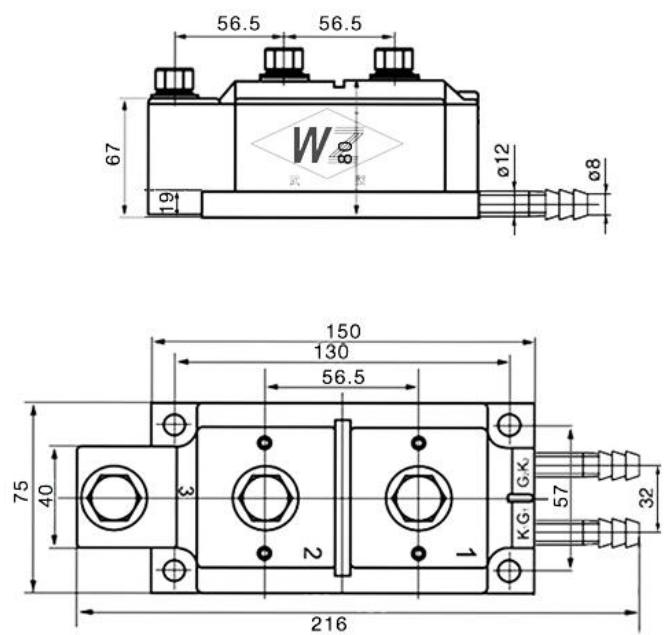

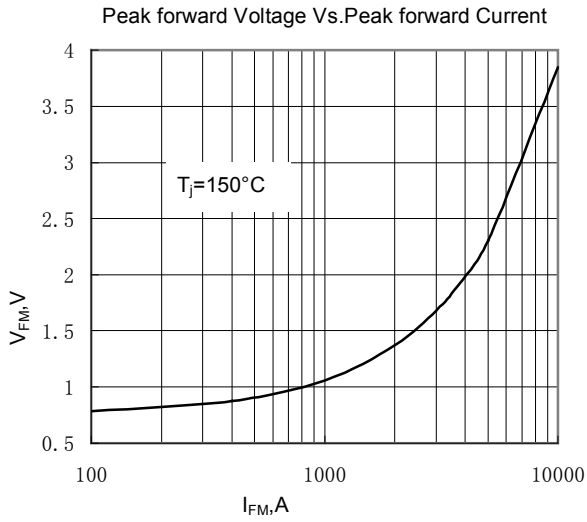

Fig.1

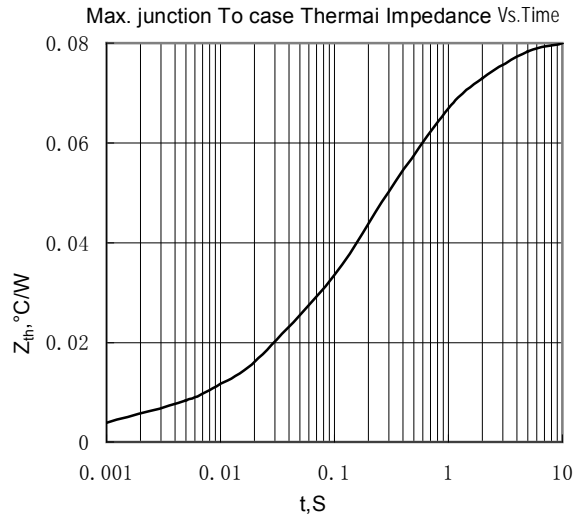

Fig.2

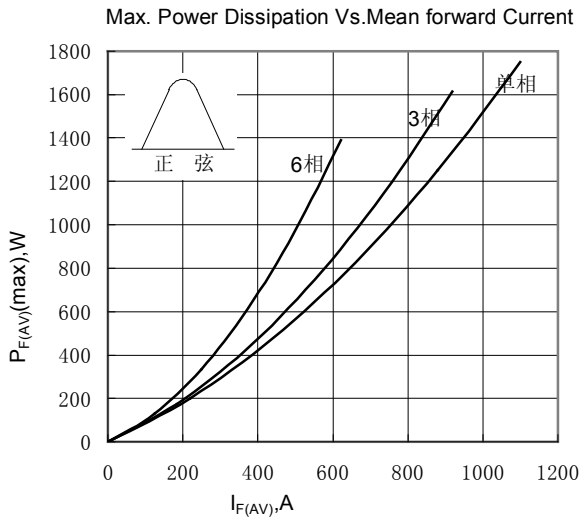

Fig.3

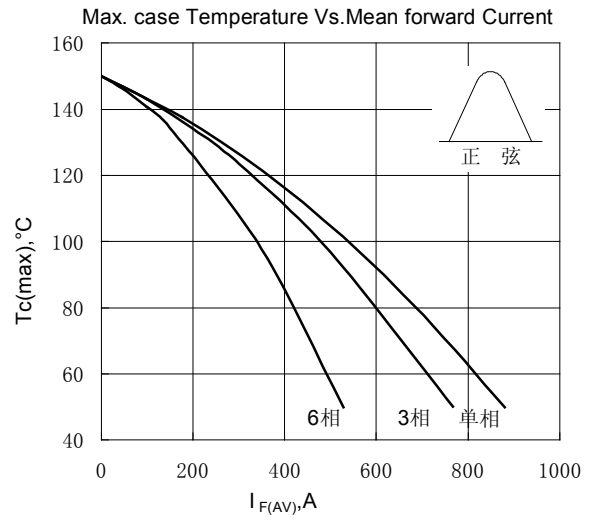

Fig.4

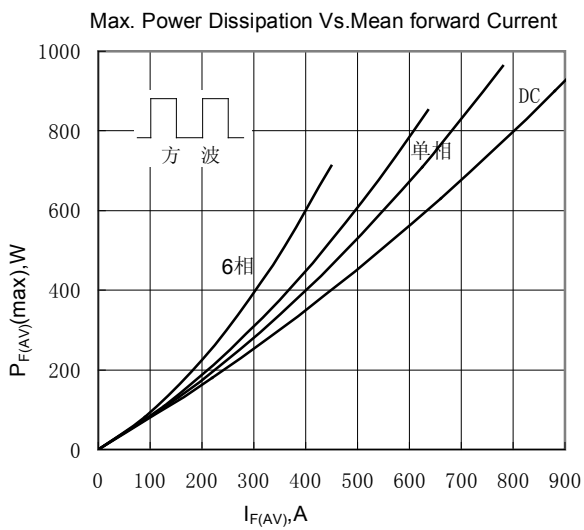

Fig.5

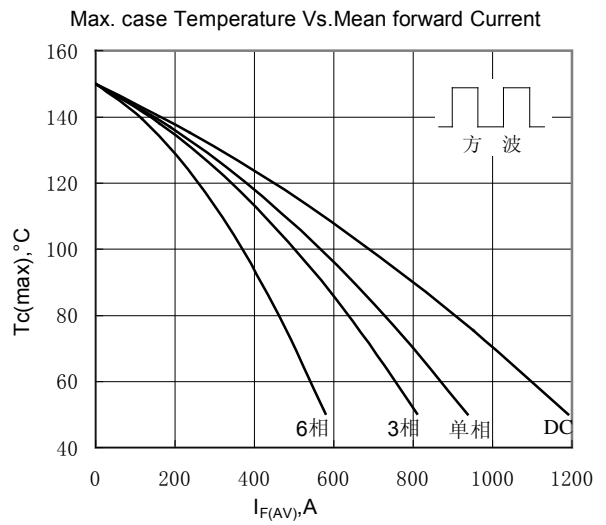
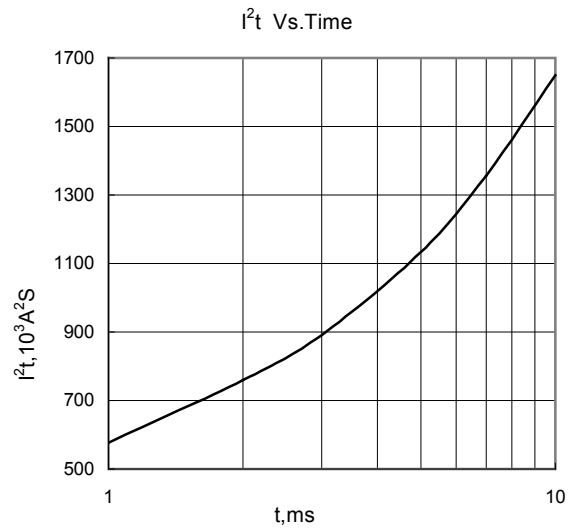
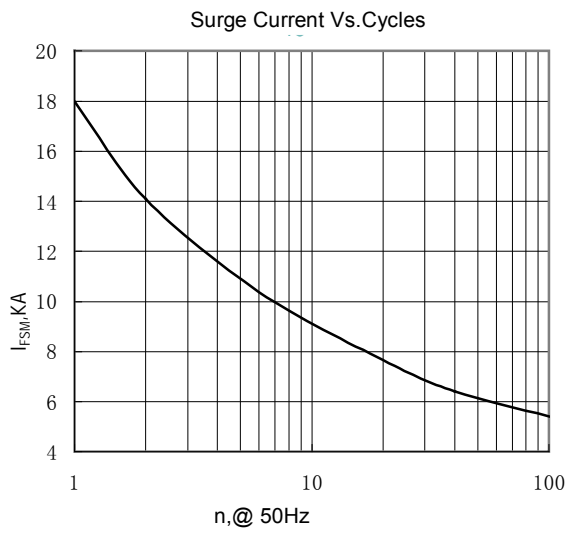

Fig.6



Wuhan Wuzheng Rectifier Co., Ltd

Add: NO. 73 Gaoxin Five Road, East Lake New Technology Development Zone, Wuhan City, Hubei province.

Tel : 86-27-87001995

Fax: 86-27-87180920

Email: info@techele.com

Web: www.techele.com/en

cn-techele.en.alibaba.com