

ZP6400A-B

STANDARD RECOVERY DIODE



Features

- Low forward voltage drop
- Soft recovery
- Hermetic metal cases with ceramic insulators

Application

- Inverters and choppers
- AC. motor control
- Snubber and free-wheeling diodes

$I_{F(AV)}$	6400A
V_{RRM}	200-1000V
I_{FSM}	60KA
I^2t	18000KA ² S

SYMBOL		PARAMETERS	TESTING CONDITION	$T_j(^{\circ}C)$	VALUE S	UNIT
Current Ratings	$I_{F(AV)}$	average forward current	180° half sine wave 50Hz Double side cooled, $T_{hs}=88^{\circ}C$	170	6400	A
	$I_{F(AV)}$	average forward current	180° half sine wave 50Hz Double side cooled, $T_{hs}=55^{\circ}C$	170	8070	A
	I_{FSM}	Surge forward current	10ms half sine wave	170	60	KA
	I^2t	I^2t for fusing coordination	$VR=0.6VRRM$	170	18000	KA ² S
Characteristics	V_{RRM}	Repetitive peak reverse voltage	$V_{RRM} tp=10ms$ $V_{RSM}=V_{RRM}+100V$	170	200-1000	V
	I_{RRM}	Repetitive peak current	$V_{RM}=V_{RRM}$	170	Max.100	Ma
	V_{FM}	Peak on-state voltage	$I_{TM}=5000A, F=40KN$	25	Max.1.25	V
	V_{FO}	Threshold voltage		170	Max.0.70	V
	r_F	Forward slop resistance			Max.0.03	mΩ
	I_{rm}	Reverse recovery current	$I_{TM}=1000A, t_p=1000\mu s,$ $di/dt=-20A/\mu s, V_r=50V$	170	Max.150	A
	t_{rr}	Reverse recovery time			Max.8.0	μs
Q_{rr}	Recovery charge			Max.600	μc	
Thermal & Mechanical Data	$R_{th(j-h)}$	Thermal resistance Junction to heat sink	At 180° sine, double side cooled mounting force 40KN		Max.0.011	°C/W
	F_m	Mounting force			35-47	KN
	T_{stg}	Stored temperature			-40-170	°C
	W_t	Weight			1100	g

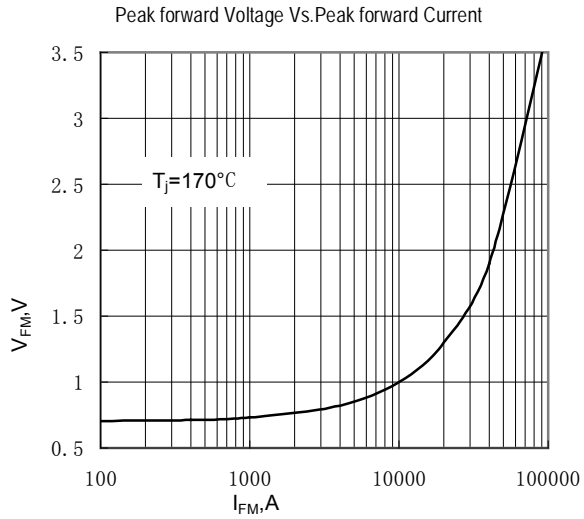

Fig.1

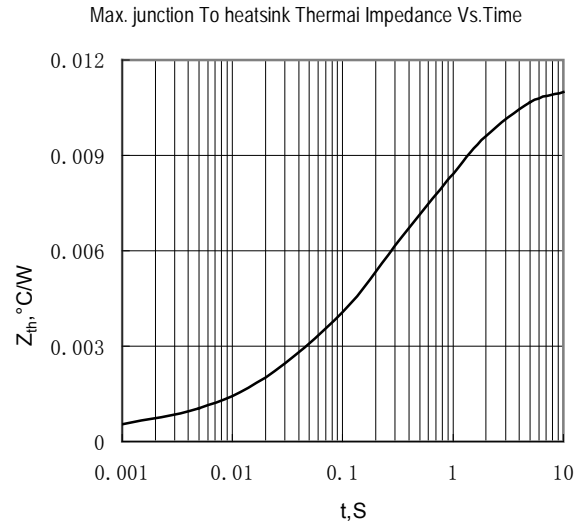

Fig.2

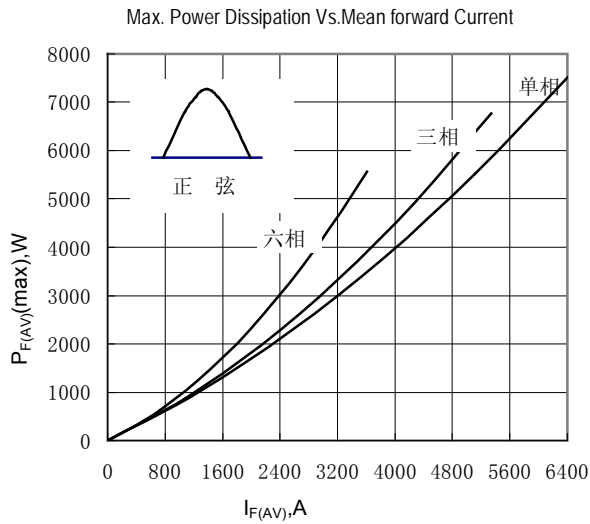

Fig.3

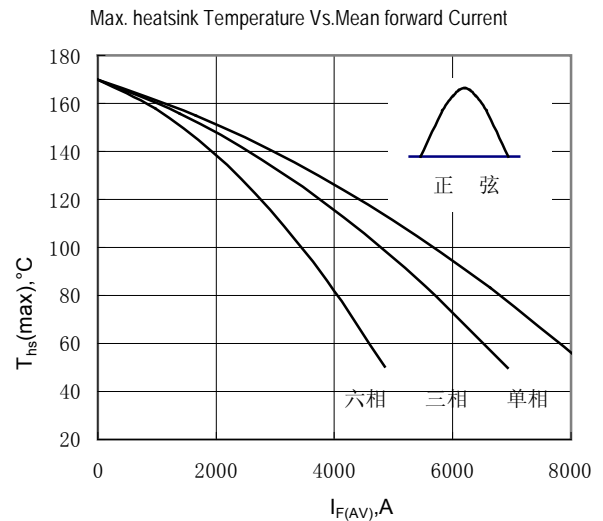

Fig.4

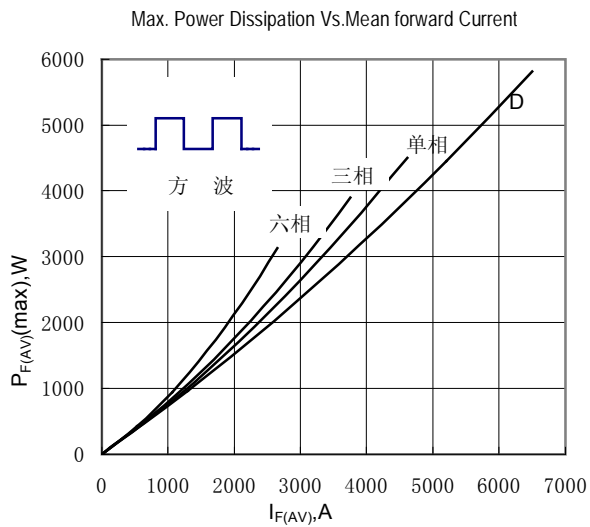

Fig.5

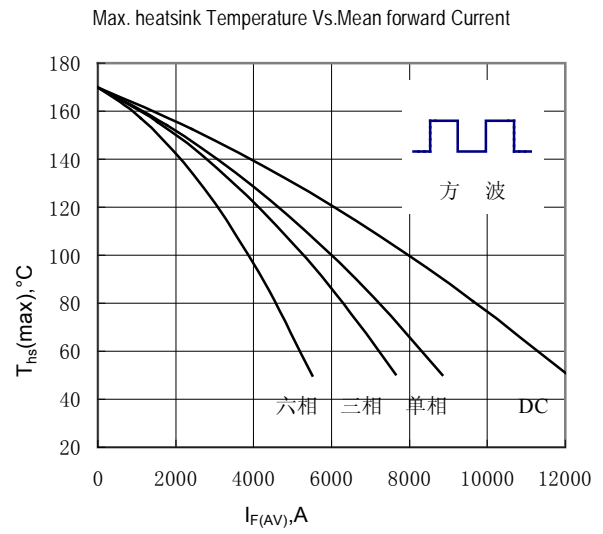

Fig.6

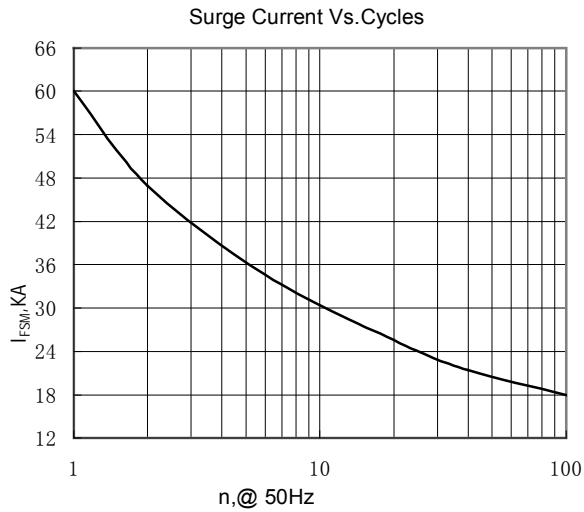

Fig.7

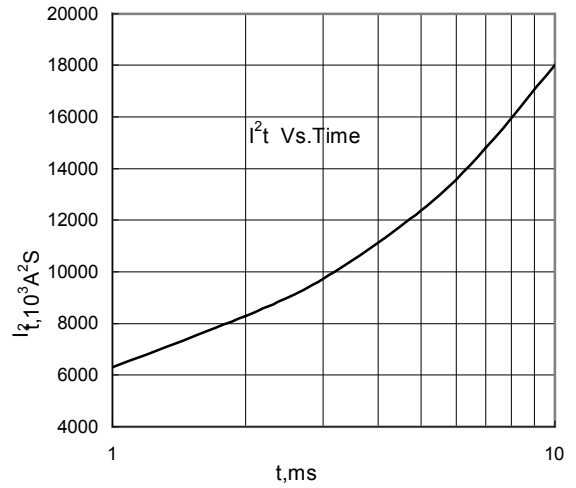
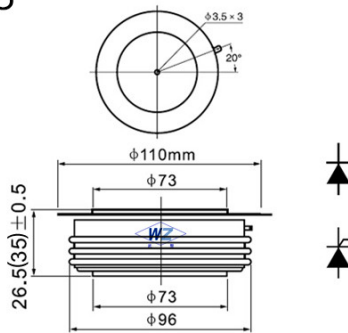

Fig.8

Fko gpukqpu<

C25



C26

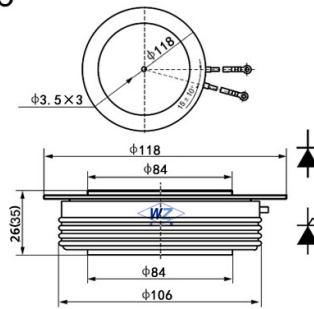

C27

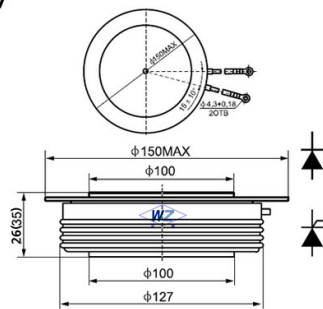

Wuhan Wuzheng Rectifier Co., Ltd

Add: NO. 73 Gaoxin Five Road, East Lake New Technology Development Zone, Wuhan City, Hubei province.

Tel : 86-27-87001995

Fax: 86-27-87180920

Email: info@techele.com

Web: www.techele.com/en

cn-techele.en.alibaba.com