

# ZP4000A-C

## STANDARD RECOVERY DIODE



### Features

- Low forward voltage drop
- Soft recovery
- Hermetic metal cases with ceramic insulators

### Application

- Inverters and choppers
- AC. motor control
- Snubber and free-wheeling diodes

$I_{F(AV)}$	4000A
$V_{RRM}$	1100-2000V
$I_{FSM}$	50KA
$I^2t$	12500KA <sup>2</sup> S

SYMBOL		PARAMETERS	TESTING CONDITION	$T_j(^{\circ}C)$	VALUES	UNIT
Current Tatings	$I_{F(AV)}$	average forward current	180° half sine wave 50Hz Double side cooled, $T_{hs}=94^{\circ}C$	150	4000	A
	$I_{F(AV)}$	average forward current	180° half sine wave 50Hz Double side cooled, $T_{hs}=55^{\circ}C$	150	5643	A
	$I_{FSM}$	Surge forward current	10ms half sine wave	150	50	KA
	$I^2t$	$I^2t$ for fusing coordination	$VR=0.6VRRM$	150	12500	KA <sup>2</sup> S
Characteristics	$V_{RRM}$	Repetitive peak reverse voltage	$V_{RRM} tp=10ms$ $V_{RSM}=V_{RRM}+100V$	150	1100-2000	V
	$I_{RRM}$	Repetitive peak current	$V_{RM}=V_{RRM}$	150	Max.200	Ma
	$V_{FM}$	Peak on-state voltage	$I_{TM}=5000A, F=78KN$	25	Max.2.0	V
	$V_{FO}$	Threshold voltage		150	Max.0.76	V
	$r_F$	Forward slop resistance			Max.0.08	mΩ
	$I_{rm}$	Reverse recovery current	$I_{TM}=1000A, t_p=1000\mu s,$ $di/dt=-20A/\mu s, Vr=50V$	150		A
	$t_{rr}$	Reverse recovery time				μs
$Q_{rr}$	Recovery charge				μc	
Thermal &Mechanical Date	$R_{th(j-h)}$	Thermal resistance Junction to heat sink	At 180° sine, double side cooled mounting force 78KN		Max.0.009	°C/W
	$F_m$	Mounting force			70-85	KN
	$T_{stg}$	Stored temperature			40-160	°C
	$W_t$	Weight			260	g

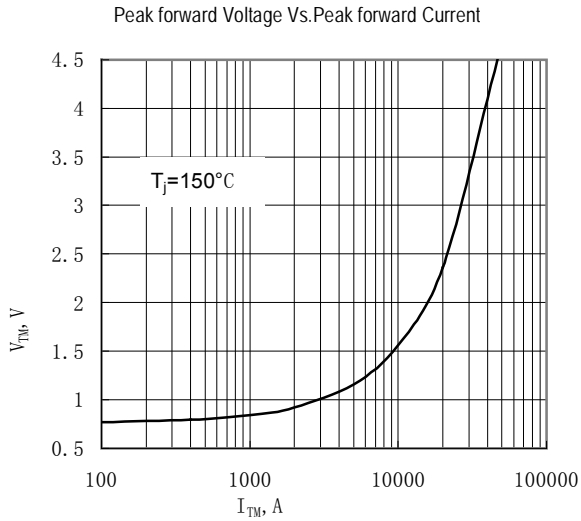

Fig.1

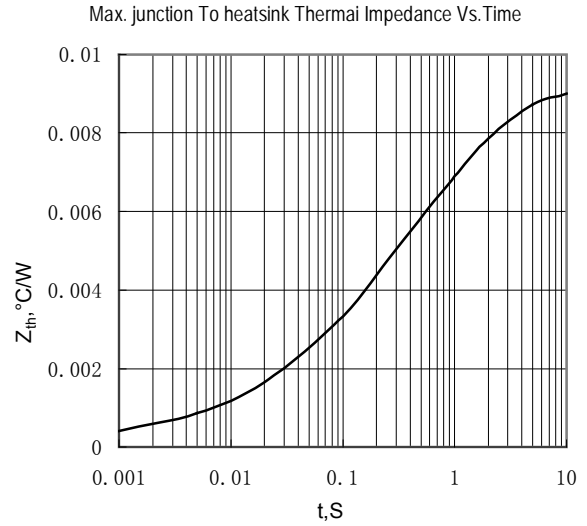

Fig.2

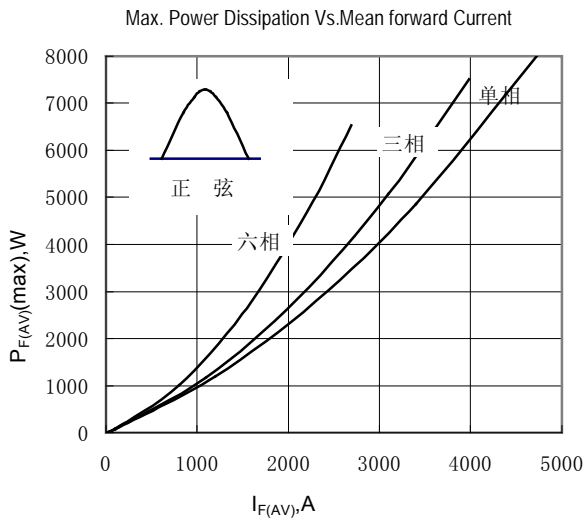

Fig.3

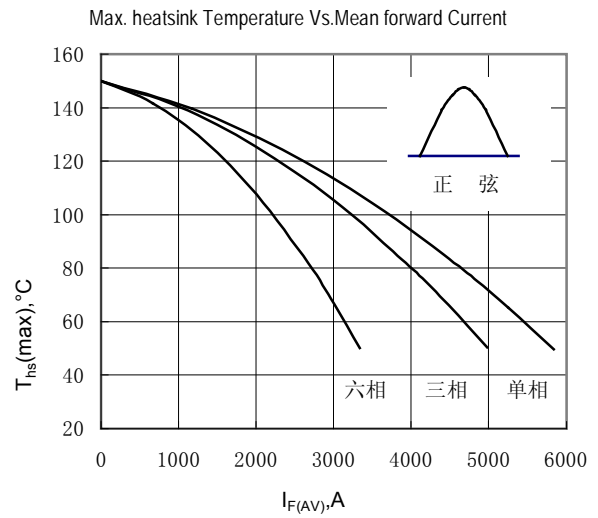

Fig.4

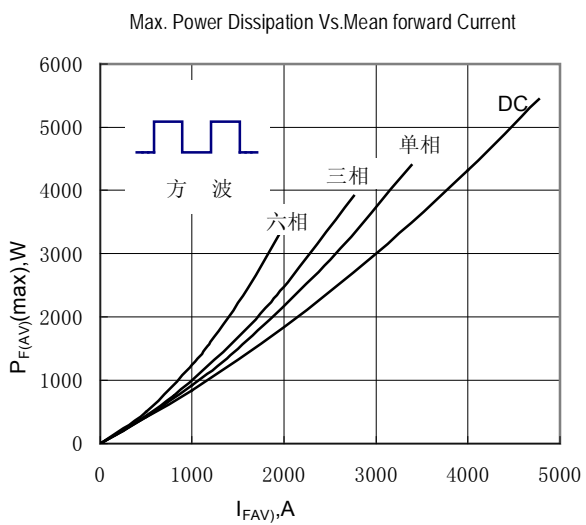

Fig.5

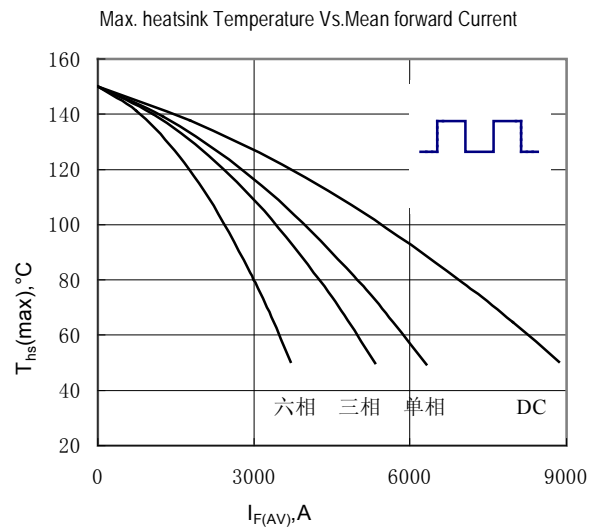

Fig.6

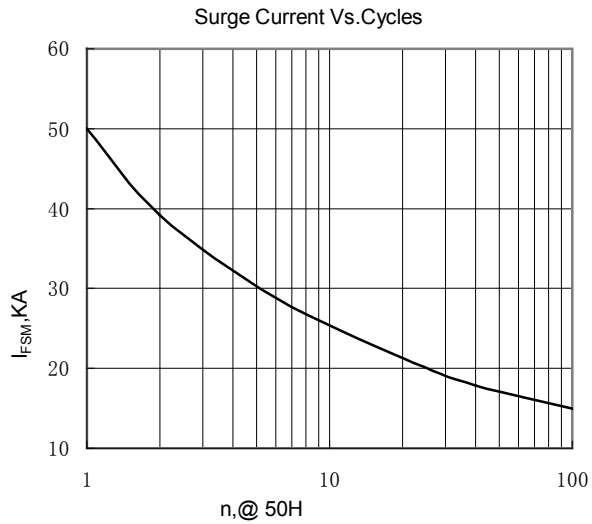

Fig.7

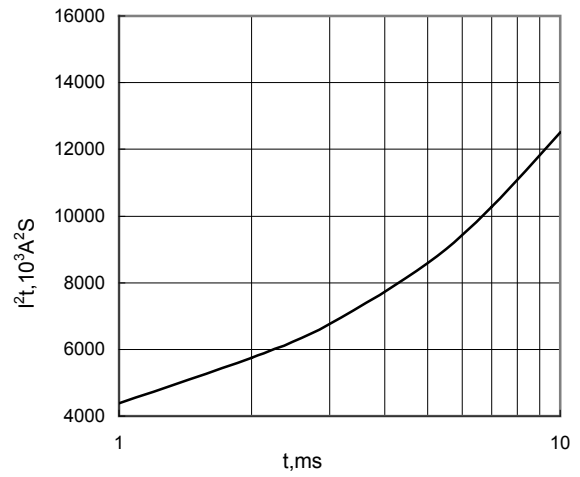
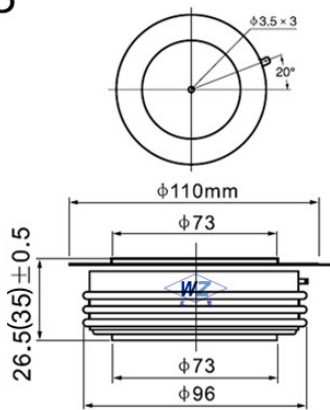

Fig.8

Dimensions:

C25



C26

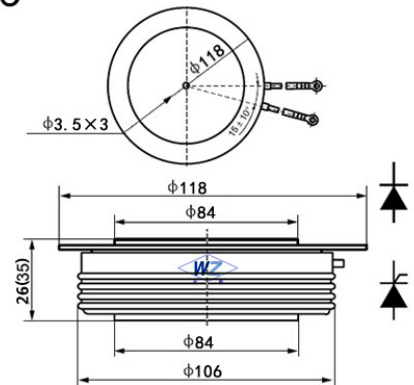

## Wuhan Wuzheng Rectifier Co., Ltd

**Add:** NO. 73 Gaoxin Five Road, East Lake New Technology Development Zone, Wuhan City, Hubei province.

**Tel :** 86-27-87001995

**Fax:** 86-27-87180920

**Email:** info@techele.com

**Web:** www.techele.com/en

cntechele.en.alibaba.com