

ZP400A-C



STANDARD RECOVERY DIODE

Features

Low forward voltage drop
Soft recovery
Hermetic metal cases with ceramic insulators

Application

Inverters and choppers
AC. motor control
Snubber and free-wheeling diodes

$I_{F(AV)}$	400A
V_{RRM}	1100-2000V
I_{FSM}	5.6KA
I^2t	160KA ² S

SYMBOL		PARAMETERS	TESTING CONDITION	$T_j(^{\circ}C)$	VALUES	U NI T
Current Tatings	$I_{F(AV)}$	average forward current	180° half sine wave 50Hz Double side cooled, $T_{hs}=119^{\circ}C$	150	400	A
	$I_{F(AV)}$	average forward current	180° half sine wave 50Hz Double side cooled, $T_{hs}=55^{\circ}C$	150	929	A
	I_{FSM}	Surge forward current	10ms half sine wave $V_R=0.6V_{RRM}$	150	5.6	KA
	I^2t	I^2t for fusing coordination		150	160	KA ² S
Characteristics	V_{RRM}	Repetitive peak reverse voltage	$V_{RRM} t_p=10ms$ $V_{RSM}=V_{RRM}+100V$	150	1100-2000	V
	I_{RRM}	Repetitive peak current	$V_{RM}=V_{RRM}$	150	Max.30	Ma
	V_{FM}	Peak on-state voltage	$I_{TM}=1200A, F=7.0KN$	25	Max.1.8	V
	V_{FO}	Threshold voltage		150	Max.1.06	V
	r_F	Forward slop resistance			Max.0.35	mΩ
	I_{rm}	Reverse recovery current	$I_{TM}=1000A, t_p=1000\mu s,$ $di/dt=-20A/\mu s, V_r=50V$	100	Max.80	A
	t_{rr}	Reverse recovery time			Max.4.0	μs
Q_{rr}	Recovery charge	Max.160			μc	
Thermal &Mechanical Date	$R_{th(j-h)}$	Thermal resistance Junction to heat sink	At 180° sine, double side cooled mounting force 9.0KN		Max.0.055	°C/ W
	F_m	Mounting force			5.3 -10	KN
	T_{stg}	Stored temperature			-40-160	°C
	W_t	Weight			80	g

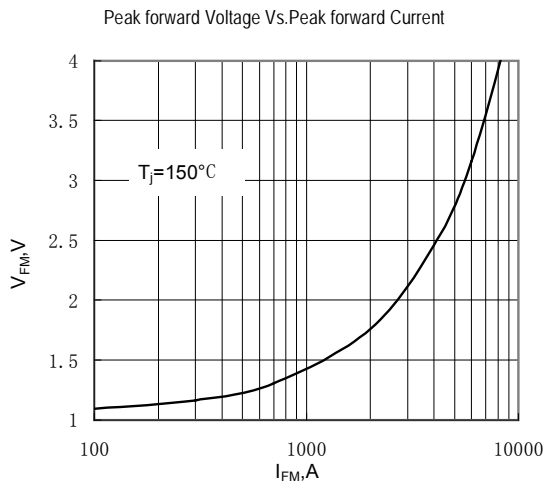

Fig.1

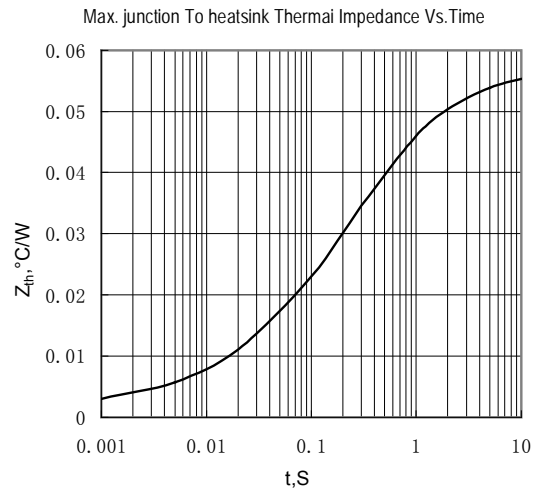

Fig.2

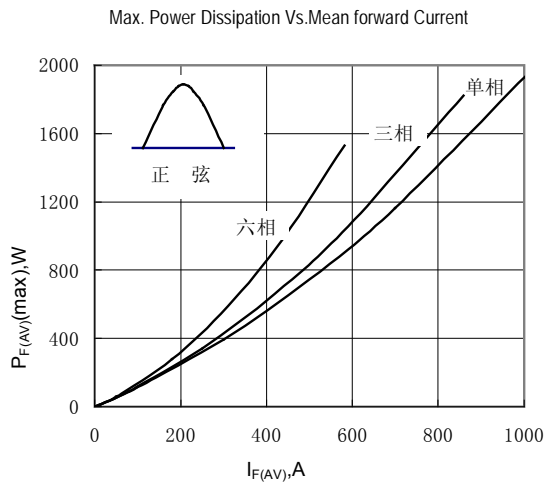

Fig.3

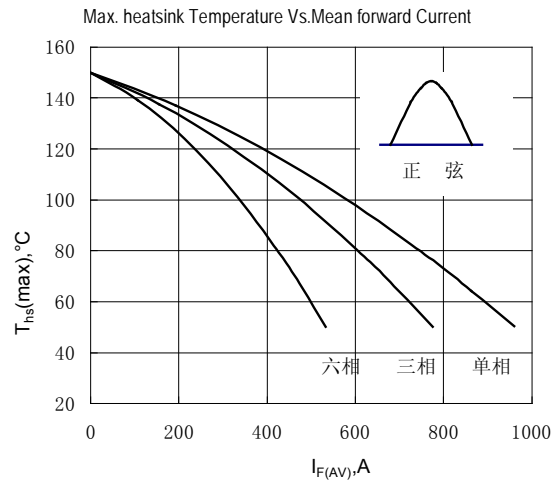

Fig.4

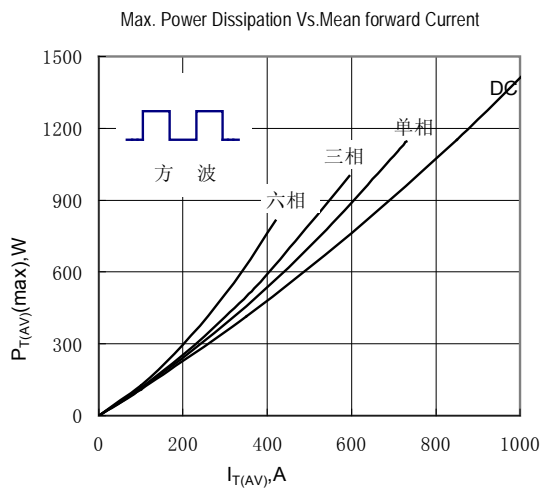

Fig.5

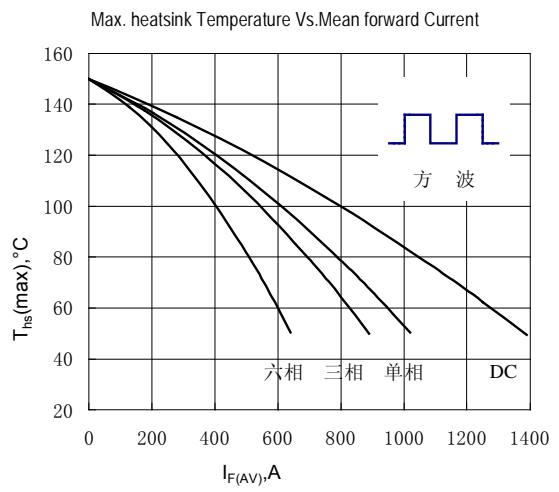
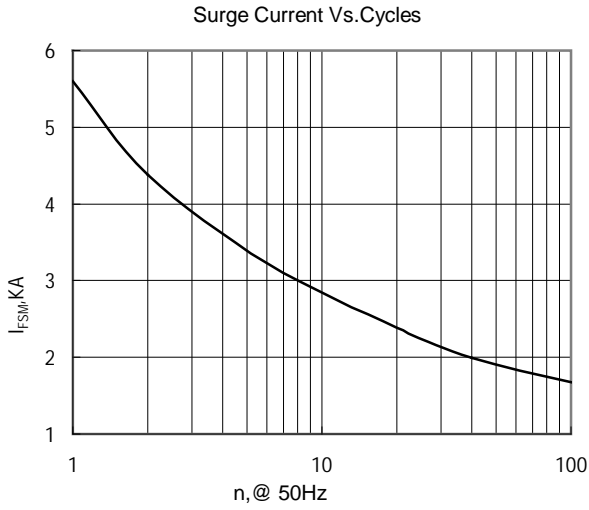
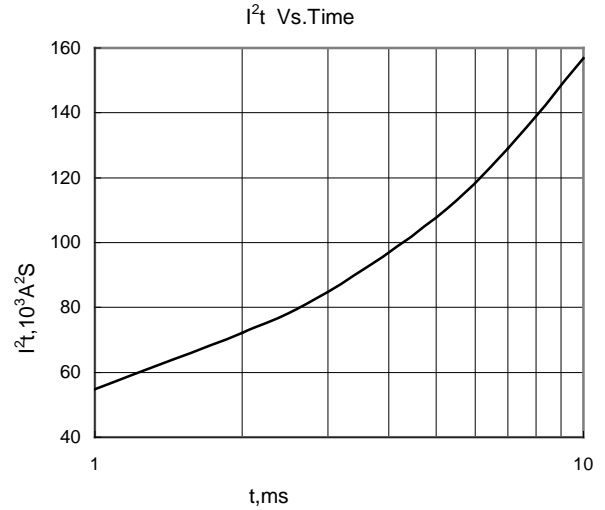

Fig.6



Øä Ę



Øä Ę

F lo gpukqu<

C8

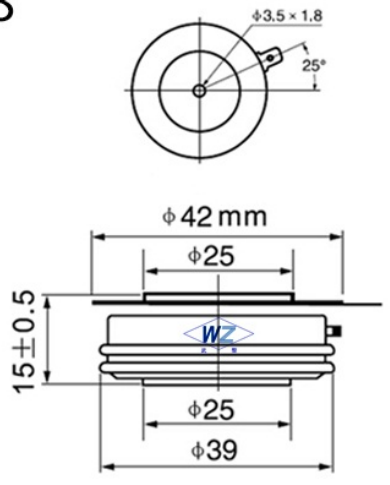

C4

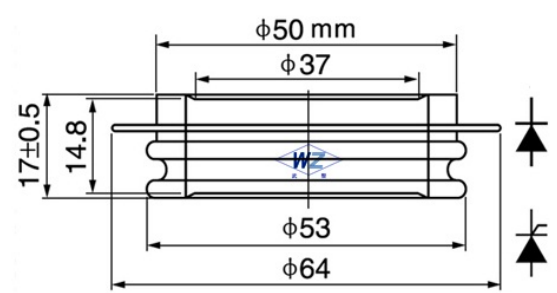

Wuhan Wuzheng Rectifier Co., Ltd

Add: NO. 73 Gaoxin Five Road, East Lake New Technology Development Zone, Wuhan City, Hubei province.

Tel : 86-27-87001995

Fax: 86-27-87180920

Email: info@techele.com

Web: www.techele.com/en

cn-techele.en.alibaba.com